



Rocky Mountain Metals, Inc

Manufacturer of Standard and Custom Hollow
Metal Doors, Frames and Windows

Index

Introduction	3
List of References	
Educational	4
Medical Care	5
Municipal, Military and Governmental	6
Corporate, Retail and Commercial	7
Hotels	8
Libraries and Casinos	9
Hollow Metal Doors	
General Information	10
Door Details	11
1100 Polystyrene Core	12
1200 Steel Stiffened	13
1500 Lead Lined	13
1300 Temperature Rise	14
1600 Dutch Doors	15-16
Hollow Metal Frames	
General Information	17-18
Welded Frames	19
Knockdown (KD) Frames	20
Pocket Frames	21
Custom Frames	22
Tornado Resistant Opening	23
Frame Details	24
1400 Door	25
Leadership in Energy and Environmental Design	26
Contact Information	27
Buy America Act	28
Certifications	28



Rocky Mountain Metals, Inc., is a manufacturer of Standard and Custom Hollow Metal Door and Frame Products located in Raton, New Mexico, just south of the Colorado border. Established in 1988, the company has over the years, supplied hollow metal products to numerous types of facilities from small offices and schools, to prestigious corporate headquarters, hospitals and exclusive hotels.

We offer excellent service with short lead times and very competitive prices. Customized and quick quoting as well as order processing through our knowledgeable and experienced staff. By the attached references, we hope that you get an understanding of not only our capabilities, but also that we are dependable and reliable. A partner you can count on.

Rocky Mountain Metals, Inc. is continually expanding capabilities, improving efficiencies and upgrading production facilities to meet today's high standards for quality and customer service. Our product program consists of among others:

Hollow Metal Frames

- Face and fully welded door and window frames. From standard frames to complex customized frame configurations. If you can design it, we can build it
- Lead lined door and window frames
- Knock down frames for welding and drywall applications
- Pocket frames

Hollow Metal Doors

- Polystyrene core construction
- Steel stiffened doors
- Lead lined doors
- Temperature rise doors
- Dutch doors

Openings Solutions

- Certified and labeled Tornado Openings for Safe Rooms in compliance with FEMA P-361/ICC-500 and FEMA P-320

Labeling and fire rating under the procedures from Underwriters Laboratory (UL). Rocky Mountain Metals, Inc. is authorized to label three-sided frames and doors for up to three hours and sidelights and windows for up to 90 minutes.

All our products qualify for full LEED Credits for recycled content MR.4.1 and 4.2, as they contain more than 25% recycled material as per the LEED Definitions (100% of Post Consumer and 50% of Pre Consumer Recycled Content).

We are a member of the **National Association of Architectural Metal Manufacturers (NAAMM) and Hollow Metal Manufacturers Association (HMMA)**. Our products are manufactured in accordance with the applicable **HMMA Standards** such as HMMA 802-07 "Manufacturing of Hollow Metal Doors and Frames" and HMMA 841-07 "Tolerances and Clearances for Commercial Hollow Metal Doors and Frames". Consequently, as per these standards, we meet and or exceed the applicable ANSI/SDI criteria.

We have an experienced management team in place with solid Hollow Metal background, as well as, experience from top level positions in the Door and Hardware Industry in the US and internationally.

Please take the time to review the information in this brochure to get a better understanding of our products and services we can provide. I hope that you will find this helpful enough to give us a chance to show what we can do for you in the areas of Standard and Custom Hollow Metal .

Sincerely yours,

Clas Thelin
President
cthelin@rockymountainmetals.com

Rocky Mountain Metals, Inc. is the proud supplier of hollow metal doors, frames and/or windows for these projects

Educational Facilities - Suitable solutions for any level

Over the years we have supplied doors and frames to educational facilities all over the country. From small basic school facilities to state of the art universities and colleges. Our product program is constantly under development to cater to the ever changing life safety needs in this area. Additionally, our products are frequently used where complex and highly customized hollow metal solutions are chosen.

- | | |
|--|-------------------|
| Greenway High School | Phoenix, AZ |
| Thunderbird High School | Phoenix, AZ |
| Tramonto Ridgeline Academy | Phoenix, AZ |
| Western School of Science and Technology | Phoenix, AZ |
| Mammoth Middle School | Mammoth Lakes, CA |
| San Diego State University | San Diego, CA |
| Dakota Ridge State University | Littleton, CO |
| Andre Agassi College Prep Academy | Las Vegas, NV |
| Clifford J. Lawrence Jr. High | Las Vegas, NV |
| Hollingsworth Elementary School | Las Vegas, NV |
| Linda Rankin Givens Elementary School | Las Vegas, NV |
| Palo Verde High School | Las Vegas, NV |
| Petersen Elementary School | Las Vegas, NV |
| Rancho High School | Las Vegas, NV |
| UNLV Campus | Las Vegas, NV |
| Rio Grande High School | Albuquerque, NM |
| Fort Wingate Elementary School | Fort Wingate, NM |
| Santa Fe Indian School | Santa Fe, NM |



**URI College of Pharmacy
Kingston, RI**

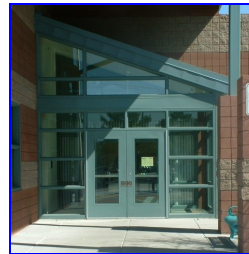

**Petersen Elementary
School
Las Vegas, NV**

- | | |
|--|----------------------|
| University of Rhode Island-College of Pharmacy | Kingston, RI |
| JFK Elementary School | Corpus Christi, TX |
| George W. Truett Elementary School | Dallas, TX |
| Decatur Elementary School | Decatur, TX |
| Everman Joe C Bean High School | Everman, TX |
| TCU Annie Richardson Bass Building | Fort Worth, TX |
| Frenship New Elementary School | Wolfforth, TX |
| Sam Houston Elementary School | La Feria, TX |
| Georgetown High School | Georgetown, TX |
| Texas Tech University—Architectural Bldg. | Lubbock, TX |
| Alice Ponder Elementary School | Mansfield, TX |
| Brooks Wester Middle School | Mansfield, TX |
| Glenn Harmon Elementary School | Mansfield, TX |
| J L Boren Elementary School | Mansfield, TX |
| Rogene Worley Middle School | Mansfield, TX |
| Barbara Fasken Elementary School | Midland, TX |
| Southwest Elementary School | Midland, TX |
| Judith A. Resnik Elementary School | San Antonio, TX |
| Boulter Middle School | Tyler, TX |
| Southwest Legacy High School | Von Ormy, TX |
| North Elementary School | White Settlement, TX |

Rocky Mountain Metals, Inc. is the proud supplier of hollow metal doors, frames and/or windows for these projects

Medical Care Facilities - From clinics to full size hospitals

The width of our products as well as our capability to supply anything from a simple door opening to custom hollow metal configurations of almost any size and complexity has made us a favored choice when it comes to medical care facilities. We can competitively supply products and solutions on all different levels, from a small clinic to full scale hospitals like the VA Hospital in Denver and Walter Reed Army Medical Center. This has gained us substantial expertise in the special products and needs in this area.

- | | |
|----------------------------------|-----------------|
| Mayo Clinic | Scottsdale, AZ |
| Banner Estrella Medical Center | Phoenix, AZ |
| Clovis Community Medical Center | Clovis, CA |
| Veterans Affairs Hospital | Aurora, CO |
| D.I. Medical and Research Center | Denver, CO |
| Mercy Medical Life Safety | Denver, CO |
| Poudre Valley Hospital | Denver, CO |
| Greely Hospital | Greely, CO |
| Sterling Medical Center | Sterling, CO |
| St. Catherine Cancer Center | Garden City, KS |



**Walter Reed Medical Center
Bethesda, MD**



**Georgetown Behavioral Health Institute
Georgetown, TX**

- | | |
|--|----------------|
| Annapolis Health Clinic | Annapolis, MD |
| Walter Reed Army Medical Center | Bethesda, MD |
| Walter Reed Behavioral Health Learning Center | Bethesda, MD |
| Henderson Hospital | Henderson, NV |
| Mountain View Hospital | Las Vegas, NV |
| Mountain View Regional Medical | Las Vegas, NV |
| Sunrise Hospital | Las Vegas, NV |
| UMC Trauma Center | Las Vegas, NV |
| Behavioral Health Clinic | Fort Brigg, NC |
| Comanche County Memorial Hospital | Lawton, OK |
| Connors State Allied Health & Nursing Facility | Muskogee, OK |
| Texas Rehabilitation Hospital | Arlington, TX |
| Matagonda Hospital | Bay City, TX |
| Presbyterian Hospital | Denton, TX |
| Forest Park Medical Center | Fort Worth, TX |
| Mesa Springs Hospital | Fort Worth, TX |
| Sundance Psychiatric Hospital | Garland, TX |
| Georgetown Behavioral Health Institute | Georgetown, TX |
| Community Health Center | Lubbock, TX |
| CWC Health Science | Riverton, WY |

Rocky Mountain Metals, Inc. is the proud supplier of hollow metal doors, frames and/or windows for these projects

Municipal, Military and Governmental Facilities - Security and Safety

In today's society security and safety are top priorities for most municipal, military and governmental facilities. We are proud of the confidence that our customers put on us and our ability to provide this for different openings and other hollow metal solutions. With a strong base in the Colorado, Texas and Nevada areas we have also been trusted to provide supply our products to other areas.

Davis-Monthan AFB-Aerospace Maintenance & Regeneration Group
F-35 Squadron Ops
4th ID CAB Consolidated Battalion HQ
Chemical Science Building
Company Operations Facility
Division Headquarters
Mountain View Ops
Visiting Officers Quarters
German Air Facility
Taos County Administration and Detention
Cold Creek Prison
Clark County Detention Center
Federal Justice Tower
Juvenile Treatment Facility
Las Vegas Metropolitan Police Department
Las Vegas Metropolitan Police Department – Fingerprint Bureau
Regional Justice Center
Visiting Officers Quarters
Lovelock Prison
McKinley County Justice Complex
National Security and Science Building
Visiting Officers Quarters
Sheppard Air Force Base
Visiting Officers Quarters
DFW Airport Terminal E
West Memorial Place
Midland Municipal Courts
Bexar Metro 911 Call Center (FEMA)
P-251 Training Facility & Hangar Naval Air Station
Army Aviation
AFB, Wyoming

Davis-Monthan AFB, AZ
Luke AFB, AZ
Fort Carson, CO
Tinker AFB, OK
Fort Carson, CO
Fort Carson, CO
Buckley AFB, Aurora, CO
Peterson AFB, CO
Holloman AFB, NM
Taos, NM
Indian Springs, NV
Las Vegas, NV
Las Vegas, NV
Las Vegas, NV
Las Vegas, NV
Las Vegas, NV
Las Vegas, NV
Las Vegas, NV
Nellis AFB, NV
Lovelock, NV
Gallup, NM
Los Alamos, NM
Altus AFB, OK
Norman, OK
Dyess AFB, TX
Dallas Ft. Worth, TX
Houston, TX
Midland, TX
San Antonio, TX
Whidbey Island, WA
Warren
Wyoming



**Clark County Detention Center
Las Vegas, NV**



**Federal Justice
Tower
Las Vegas, NV**

Rocky Mountain Metals, Inc. is the proud supplier of hollow metal doors, frames and/or windows for these projects

Corporate, Retail and Commercial Buildings - Image and cost efficiency

When it comes to corporate, retail and commercial buildings the top priorities are most often image and cost efficiency. You want to be able communicate strength and success but at the same keep things under pretty tight cost control. We have been trusted to support in these efforts by a number of very successful companies.

- | | |
|--------------------------------------|--------------------|
| Intel Headquarters – Water Plant | Albuquerque, NM |
| Rush Truck Center | Commerce, CO |
| Village at the Peaks | Longmont, CO |
| ABC Studios | New York, NY |
| Ocean Spray III | Henderson, NV |
| Bonnie Lane Senior Housing | Las Vegas, NV |
| Hilton Executive Offices | Las Vegas, NV |
| Switch Super NAP 8 Data Center | Las Vegas, NV |
| Veer Towers at City Center | Las Vegas, NV |
| Mesa Microlab | Albuquerque, NM |
| Weapons Integration Facility | Los Alamos, NM |
| National Cowboy Hall of Fame | Oklahoma City, OK |
| Harley Davidson | Dallas, TX |
| KPMG Plaza at Hall Arts | Dallas, TX |
| Chase Building | Farmers Branch, TX |
| Alcon Labs | Fort Worth, TX |
| Pier One Headquarters | Fort Worth, TX |
| Merrick Pet Foods | Hereford, TX |
| Energy Plaza | Houston, TX |
| West Memorial Place | Houston, TX |
| Cabela's | Lubbock, TX |
| XTO Energy Office | Midland, TX |
| Helmerich & Payne Facility Expansion | Odessa, TX |



**Switch SuperNAP 8
Las Vegas, NV**



**West Memorial Place
Houston, TX**

Rocky Mountain Metals, Inc. is the proud supplier of hollow metal doors, frames and/or windows for these projects

Hotels - Hospitality and comfort coupled with safety and security

With Nevada and Texas as a base, we are a trusted supplier to the hospitality industry. We have a proven track record to be able to support our customers need to provide a high level of comfort but at the same time not compromise the safety and security for their guests. Our products show up in a number of very prestigious facilities and also in more cost conscious environments.

Hyatt
Ritz Carlton
Adam's Mark Hotel
Vail Marriott
The Miami Beach EDITION Hotel
Embassy Suites
Hampton Inn
Howard Hughes Parkway
Mirage Hotel Theater Center
Polo Twin Towers
Hilton Garden Inn
Winstar Hotel and Casino
Marriott North
Marriott South
Marriott
Hilton Garden Inn
Marriott
Townplace Suites

Sedona, AZ
San Francisco, CA
Denver, CO
Vail, CO
Miami, FL
Las Vegas, NV
Las Vegas, NV
Las Vegas, NV
Las Vegas, NV
Las Vegas, NV
Oklahoma City, OK
Thackerville, OK
Austin, TX
Austin, TX
Ft. Worth, TX
Lubbock, TX
Plano, TX
Vernal, UT



**The Miami Beach EDITION Hotel
Miami, FL**



**Hyatt
Sedona, AZ**



**Ritz Carlton
San Francisco, CA**

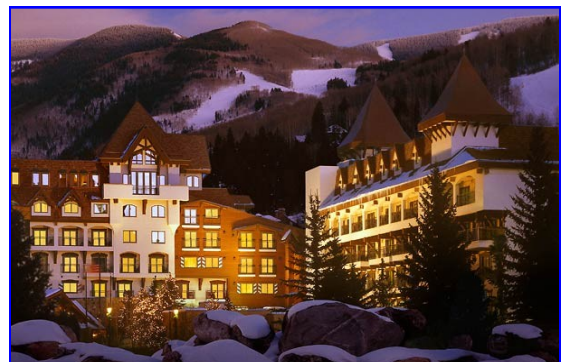

**Marriott
Vail, Colorado**

Rocky Mountain Metals, Inc. is the proud supplier of hollow metal doors, frames and/or windows for these projects

Libraries - Serenity and design

We are proud of the trust we have been shown and the opportunity we have been given to be part of the more prestigious libraries in the country. These are buildings where design and the feel of serenity are top priorities and it is certainly prestigious for a hollow metal company like Rocky Mountain Metals to support this.

JFK Library
Lied Library
TCU Mary Couts Burnett Library

Boston, MA
Las Vegas, NV
Fort Worth, TX

**JFK Library
Boston, MA**



Casinos - Money, money, money...

Our base in Las Vegas has provided us with ample opportunities to supply products to some of the most prestigious casinos in the world. Our products have proven to provide the right level of security and aesthetics to cater to this demanding market.



**Caesar's Palace
Las Vegas, NV**

**The Orleans Hotel and Casino
Las Vegas, NV**

- | | |
|------------------------------|------------------|
| Bally's Casino | Las Vegas, NV |
| Boardwalk Casino | Las Vegas, NV |
| Caesar's Palace | Las Vegas, NV |
| MGM Grand – Theatre | Las Vegas, NV |
| The Orleans Hotel and Casino | Las Vegas, NV |
| Stratosphere | Las Vegas, NV |
| Sunrise Casino | Las Vegas, NV |
| Treasure Island Casino | Las Vegas, NV |
| Winstar Hotel and Casino | Thackerville, OK |



Hollow Metal Doors

A full line of Hollow Metal Doors

- 1100 Doors with Polystyrene Core
- 1200 Steel Stiffened Doors
- 1300 Temperature Rise Doors
- 1400 Doors for Tornado Solutions
- 1500 Lead lined Doors
- 1600 Dutch Doors

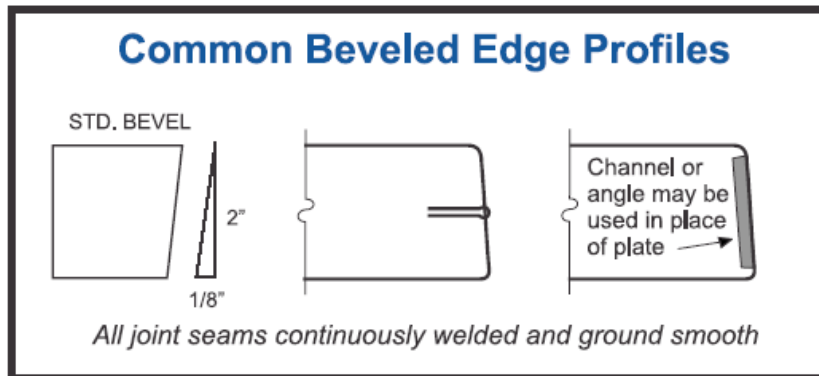
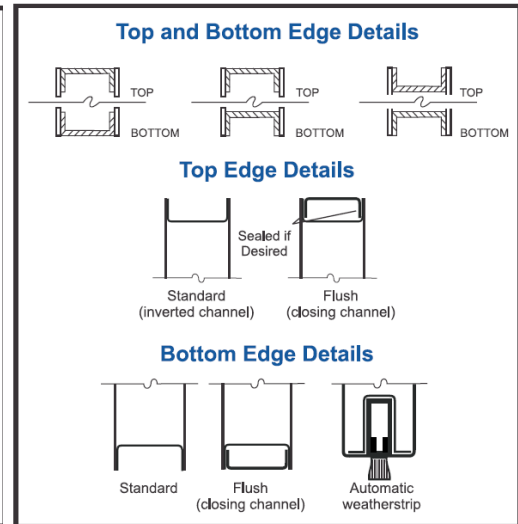
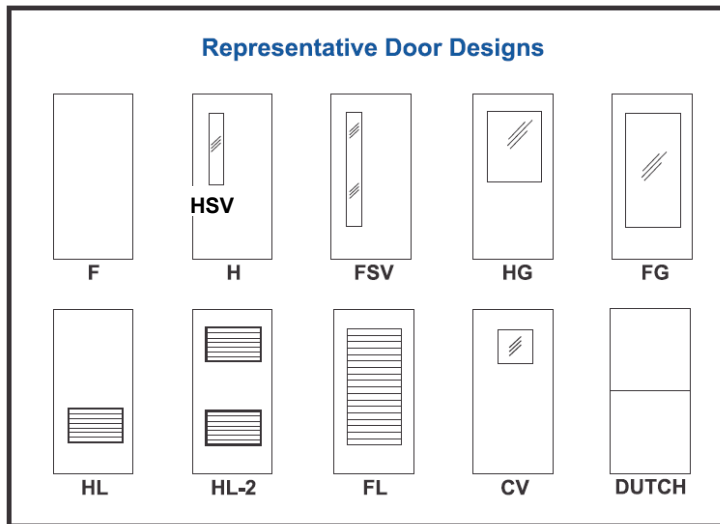

Manufacturing Tolerances

Manufacturing tolerances shall be maintained within the following limits for Doors

Width +/- 1/32 in. (.08mm)
 Height +/- 3/64 in. (1.2mm)
 Thickness +/- 1/16 in. (1.6mm)
 Hardware cutout dimensions/Template dimensions +0.015", -0"
 Hardware location +/- 1/32 in. (.08mm)

Door Details - Typical Hardware Preparations

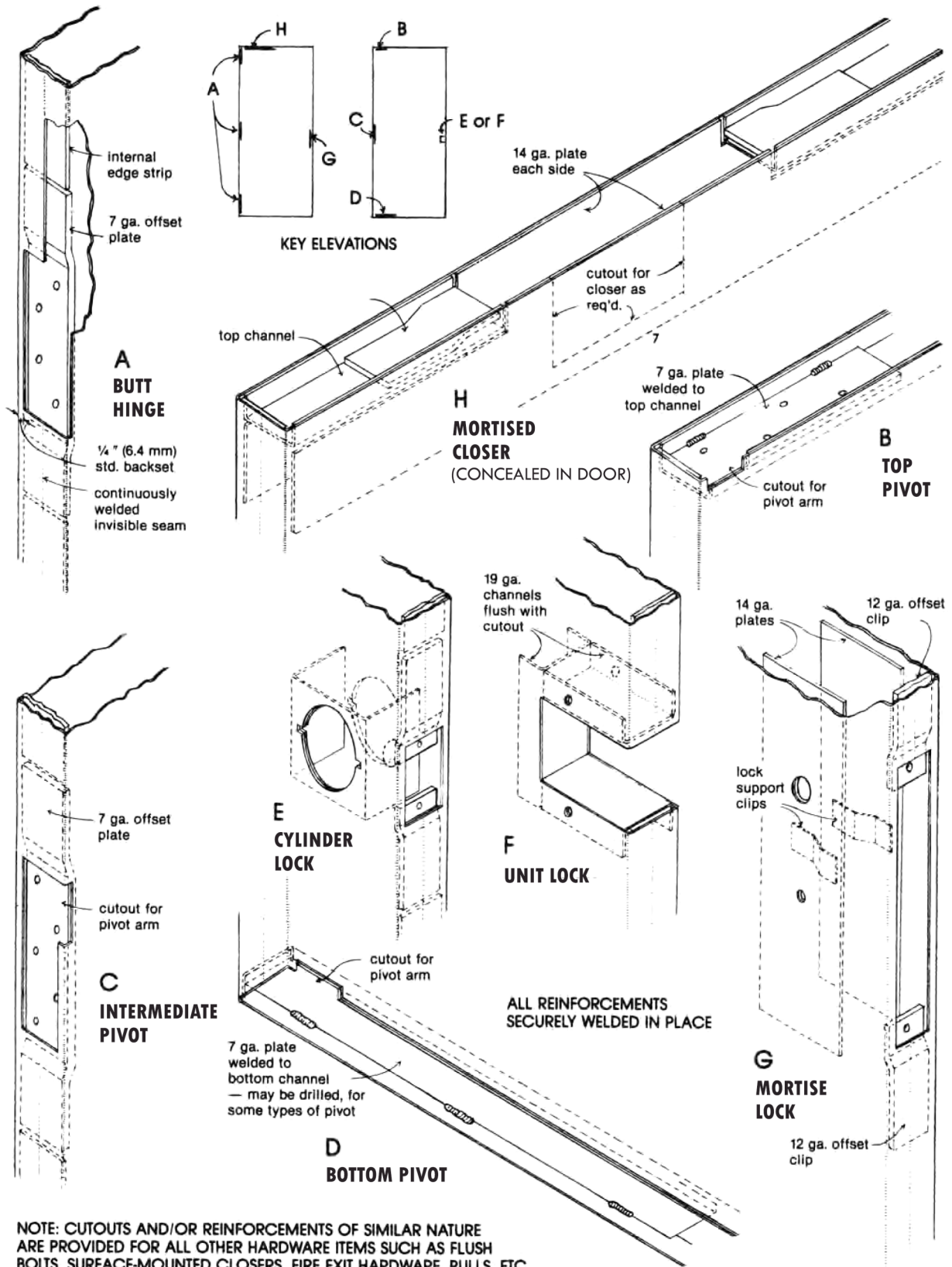

1100 Hollow Metal Door with Polystyrene Core

Face Material	Galvannealed A40 or A60 ASTM-A-653
Face thickness	12, 14, 16 and 18 Ga.
Construction	Rigid polystyrene core bonded to both face sheets
Door thickness	1 3/4" Standard
Hardware Locations	Any specified locations
Reinforcements	7 Ga. 1 1/4" x 10" joggled hinge reinforcement, drilled and tapped 12 Ga. mortise hardware tabs, drilled and tapped 14 Ga. surface hardware and trim reinforcement, drilled and tapped
Edge reinforcement	Both edges reinforced with 16 Ga. full length channels spot welded to the face sheets
Vertical edges	Fully welded with no visible seam (for doors up to 4' wide and 8' height)
Glazing/ Louvers	Glazing stops to be set for 1/4" glass (3/8" space) unless otherwise requested. Note: Glass should be cut 1/4" less than door cut out. Exposed glass opening is 1 5/16" less than cutout dimensions. Louver size is actual size of door cutout
Handing	Doors are handed
Appearance	Faces and edges free of defects, warp and buckle
Finish	Thoroughly cleaned and coated with a rust inhibiting primer meeting requirements as per ANSI/SDI A250.10

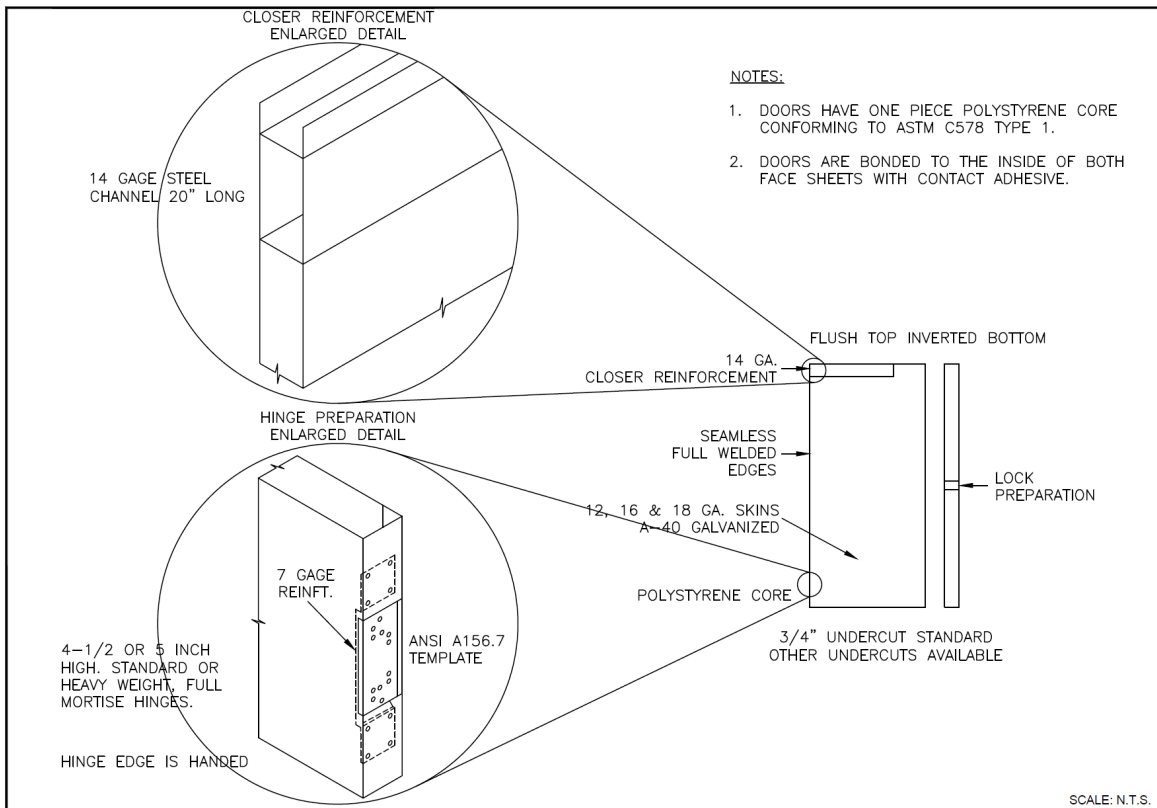

1200 Steel Stiffened Door / 1500 Lead Lined Door

Face Material	Galvannealed A40 or A60 ASTM-A-653
Face thickness	12, 14, 16 and 18 Ga.
Lead Lining	Center door lead lining (optional)
Construction	Hollow metal with vertical steel stiffeners (ribs). Space between ribs Insulated with glass wool insulation
Door thickness	1 3/4" Standard
Hardware Locations	Any specified location
Reinforcements	7 Ga. 1 1/4" x 10" joggled hinge reinforcement, drilled and tapped 12 Ga. mortise hardware tabs, drilled and tapped 14 Ga. surface hardware and trim reinforcement, drilled and tapped
Edge reinforcement	Vertical and horizontal edges reinforced with 16 Ga. (min) full length channels spot welded to the face sheets
Vertical edges	Fully welded with no visible seam (for doors up to 10' height and 4' width)
Glazing/ Louvers	Glazing stops to be set for 1/4" glass (3/8" space) unless other wise requested. Note: Glass should be cut 1/4" less than door cut out. Exposed glass opening is 1 5/16" less than cutout dimensions. Louver size is actual size of door cutout
Handing	Doors are handed
Appearance	Faces and edges free of defects, warp and buckle
Finish	Thoroughly cleaned and coated with a rust inhibiting primer meeting requirements as per ANSI/SDI A250.10
Options	UL Labeling requirements as specified

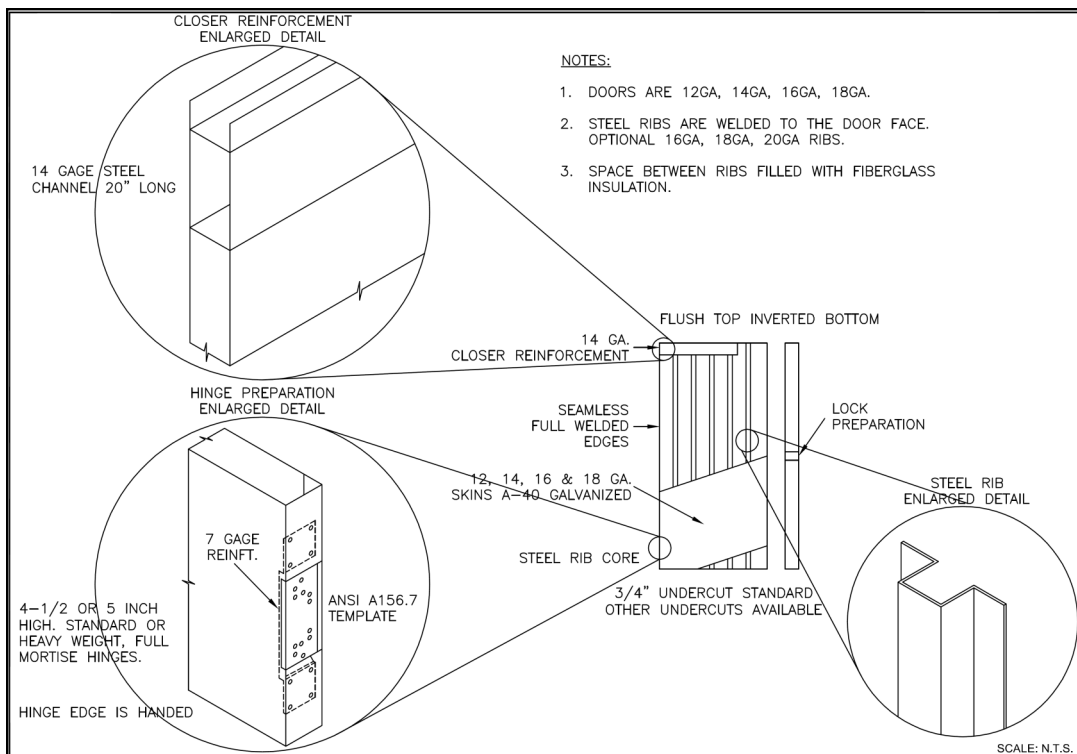

1300 Temperature Rise Door

Face Material	Galvannealed A40 or A60 ASTM-A-653
Face thickness	12, 14, 16 and 18 Ga.
Construction	Rigid mineral board core bonded to both face sheets
Door thickness	1 3/4" Standard
Hardware Location	Any specified locations
Reinforcements	7 Ga. 1 1/4" x 10" joggled hinge reinforcement, drilled and tapped 12 Ga. mortise hardware tabs, drilled and tapped 14 Ga. surface hardware and trim reinforcement, drilled and tapped
Edge reinforcement	Vertical and horizontal edges reinforced with 16 Ga. full length channels spot welded to the face sheets
Vertical edges	Fully welded with no visible seam (for doors up to 10' height and 4' width)
Glazing	Glazing stops to be set for 1/4" glass (3/8" space) unless other wise requested. Note: Glass should be cut 1/4" less than door cut out. Exposed glass opening is 1 5/16" less than cutout dimensions. Glass area up to 100 sq. inches.
Handing	Doors are handed
Appearance	Faces and edges free of defects, warp and buckle
Finish	Thoroughly cleaned and coated with a rust inhibiting primer meeting requirements as per ANSI/SDI A250.10
Temperature Options	60-180 min. Labels available for 450 degree and 250 degree temp. UL Labeling requirements as specified

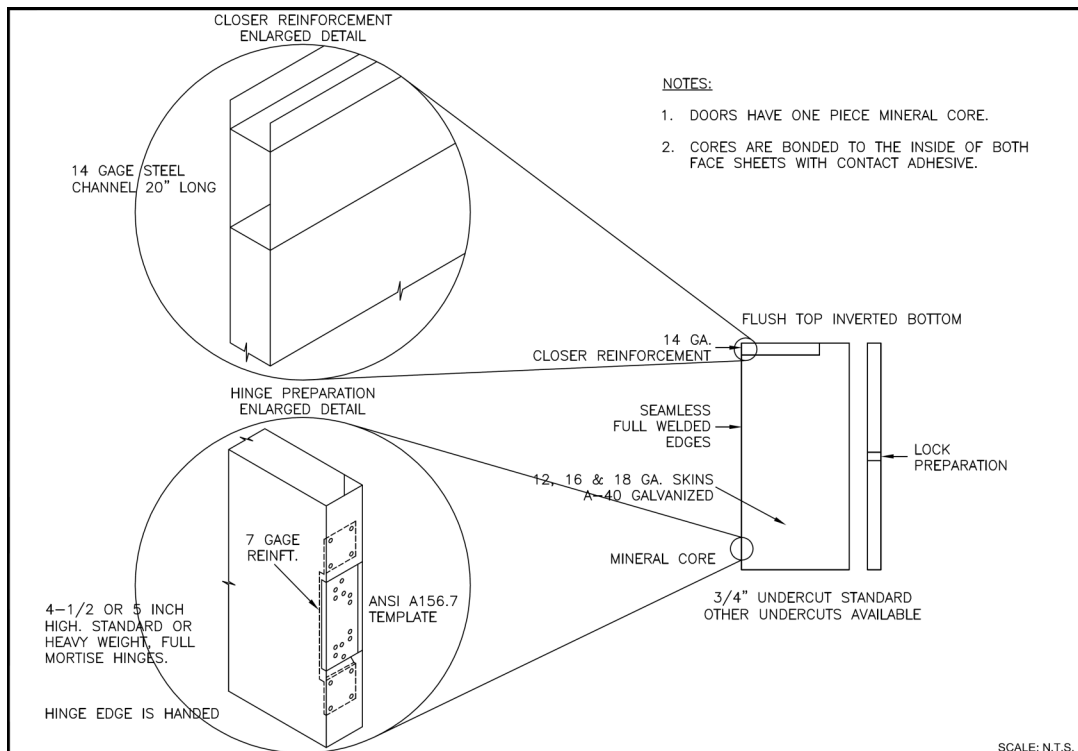

1600 Dutch Doors

Face Material	Galvannealed A40 or A60 ASTM-A-653
Face thickness	12, 14, 16 and 18 Ga.
Construction	Can be manufactured as a Polystyrene Core (1100 door) or Steel Stiffened Door (1200 door)
Door thickness	1 3/4" Standard
Hardware Locations	Any specified locations
Reinforcements	7 Ga. 1 1/4" x 10" joggled hinge reinforcement, drilled and tapped 12 Ga. mortise hardware tabs, drilled and tapped 14 Ga. surface hardware and trim reinforcement, drilled and tapped
Edge reinforcement	Both edges reinforced with 16 Ga. full length channels spot welded to the face sheets
Vertical edges	Fully welded with no visible seam (for doors up to 4' wide and 8' high)
Glazing/ Louvers	Glazing stops to be set for 1/4" glass (3/8" space) unless otherwise requested. Note: Glass should be cut 1/4" less than door cut out. Exposed glass opening is 1 5/16" less than cutout dimensions. Louver size is actual size of door cutout
Handing	Doors are handed
Appearance	Faces and edges free of defects, warp and buckle
Finish	Thoroughly cleaned and coated with a rust inhibiting primer meeting requirements as per ANSI/SDI A250.10
Options	Shelf available as specified

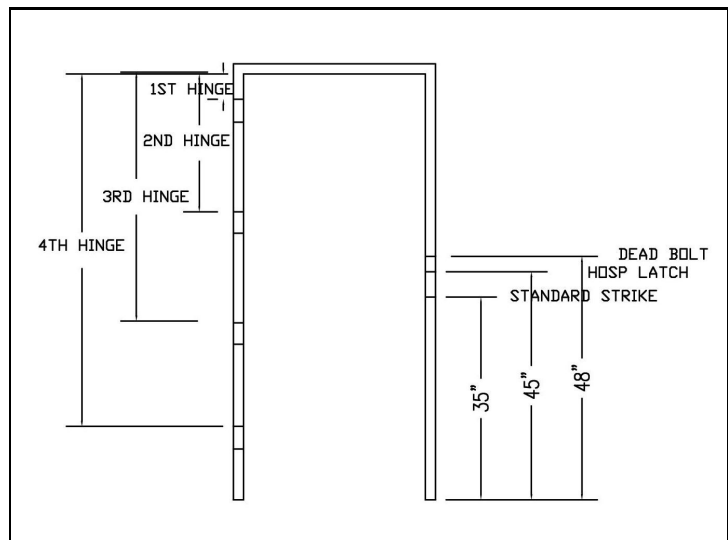
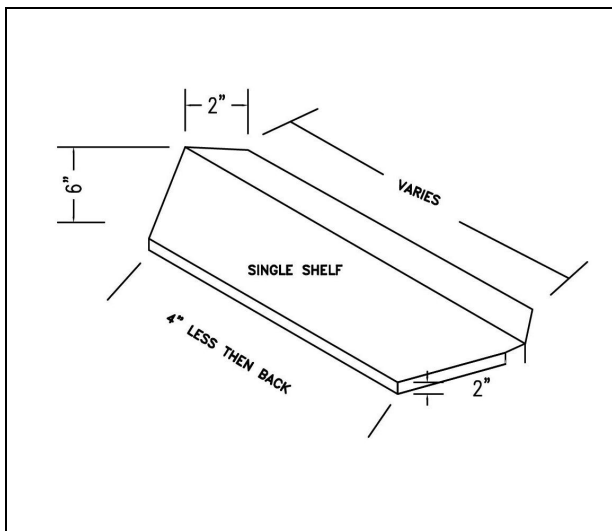

1600 Dutch Doors

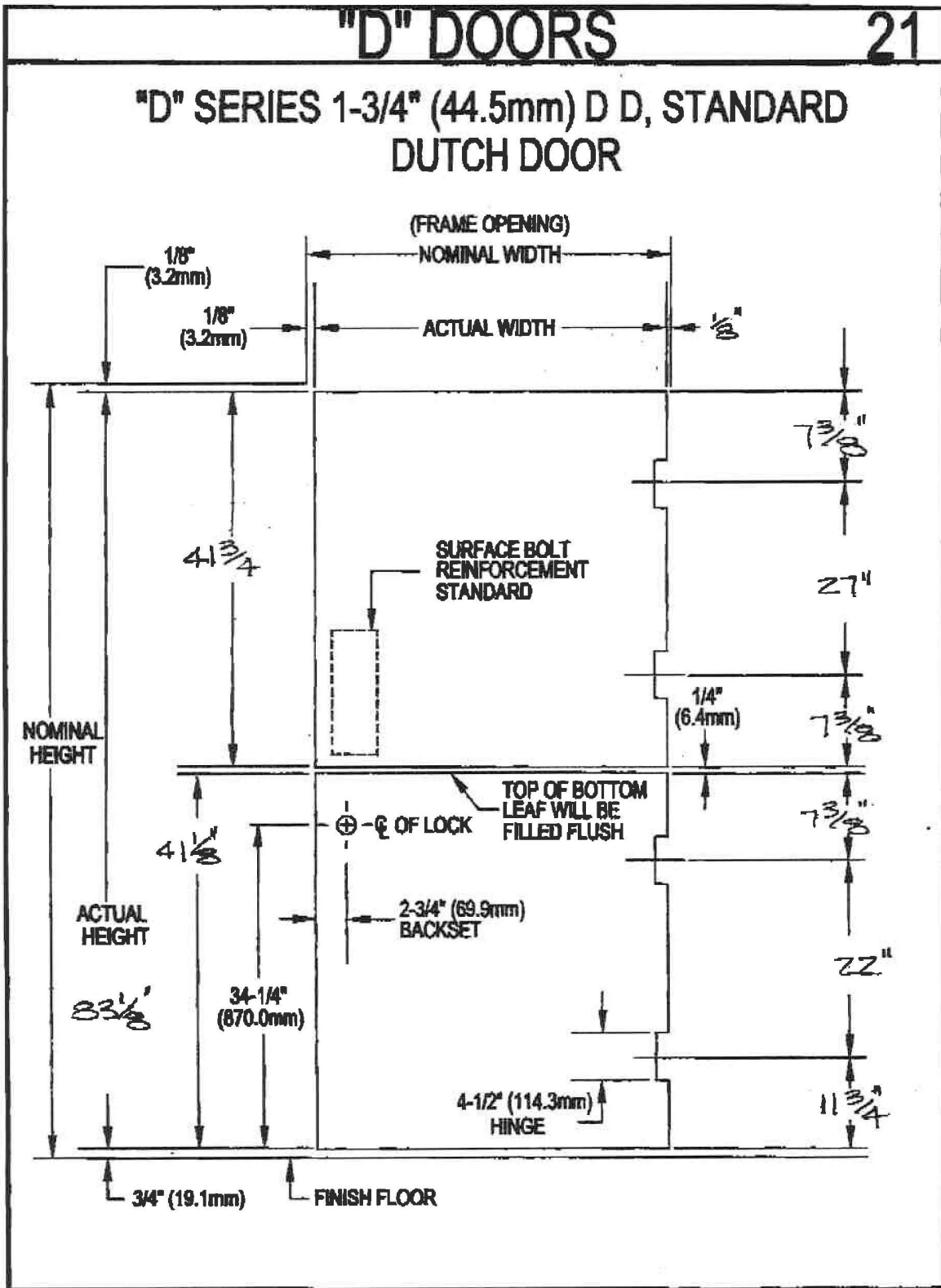

Hollow Metal Frames

A full line of standard and custom frames:

- Standard door frames, fully or face welded, optional with Hospital stops
- Window frames
- Sidelights
- Standard, window and sidelight frames can be supplied lead lined
- Knock down (KD) frames for welding
- Dry wall knock down (KD frames)
- Custom frames
- Pocket Frames
- Double Egress Frames

Manufacturing Tolerances for Frames

Frames for single door or pair of doors:

Width, measured between rabbets at the head; nominal opening width $+1/18'' - 1/32''$

Height (total length of jamb rabbet): nominal opening height $\pm 3/64''$

Frames overlapping walls to have throat dimension $1/8''$ greater than dimensioned wall thickness to accommodate irregularities in wall construction.

Standard frame anchors

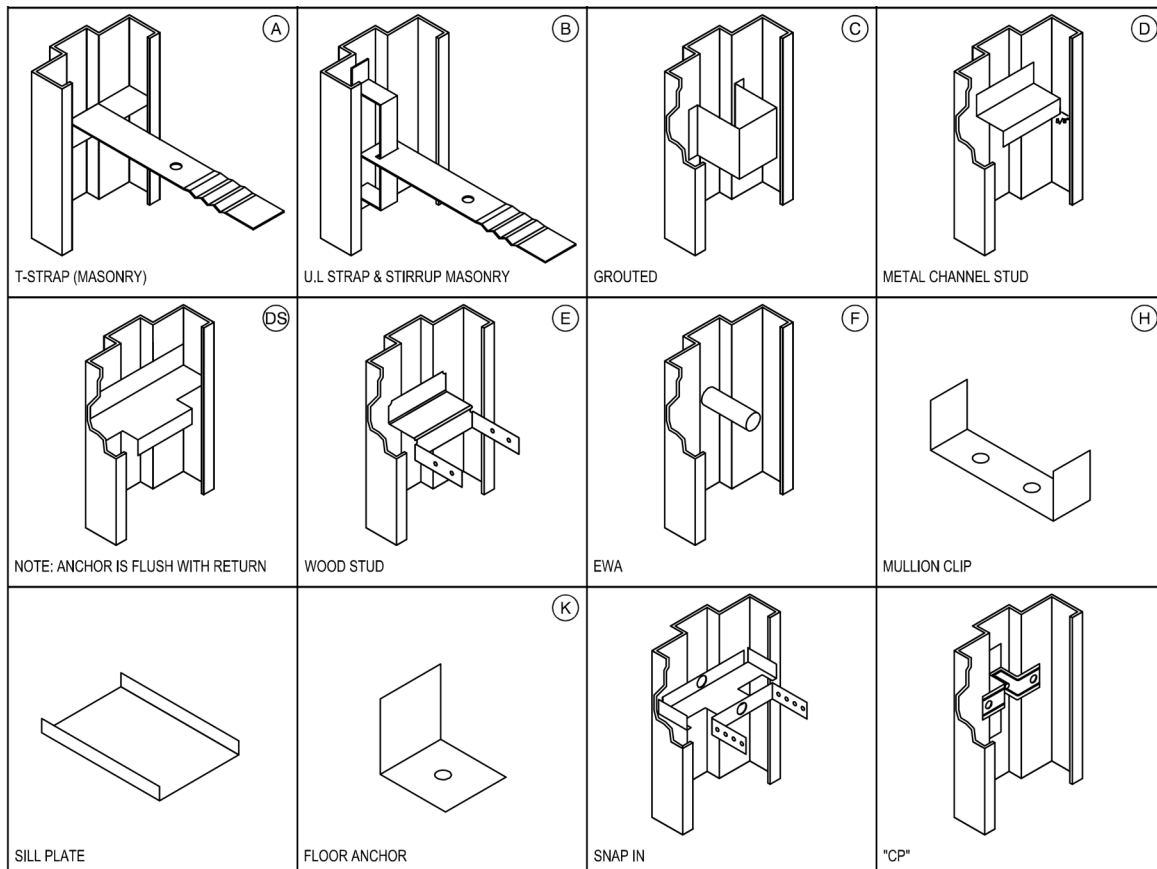

Hollow Metal Frames

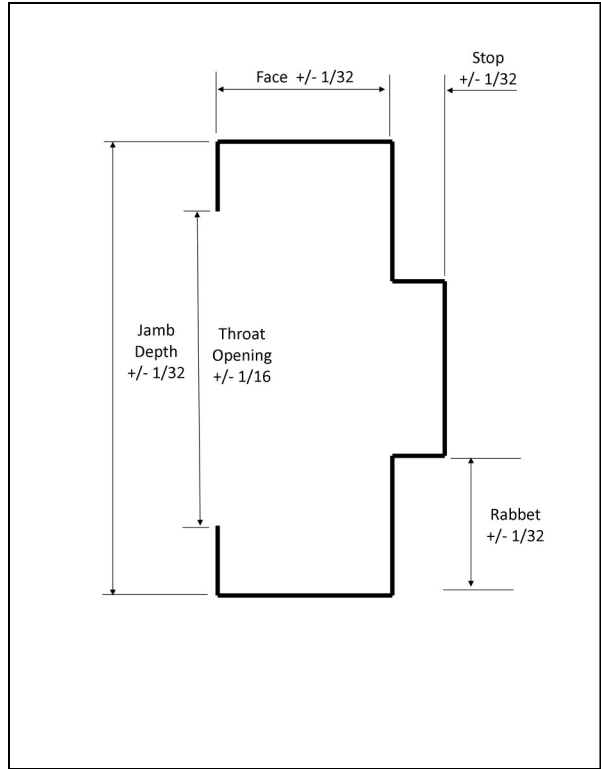

Standard frame sections

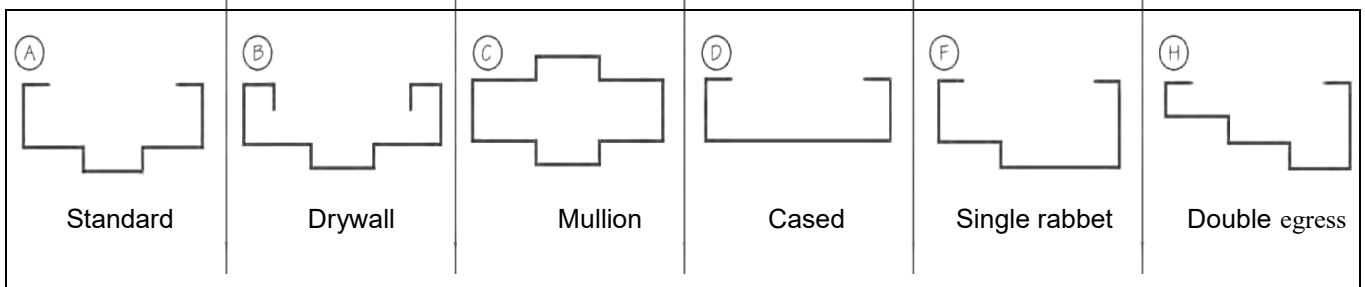

Standard frame elevations

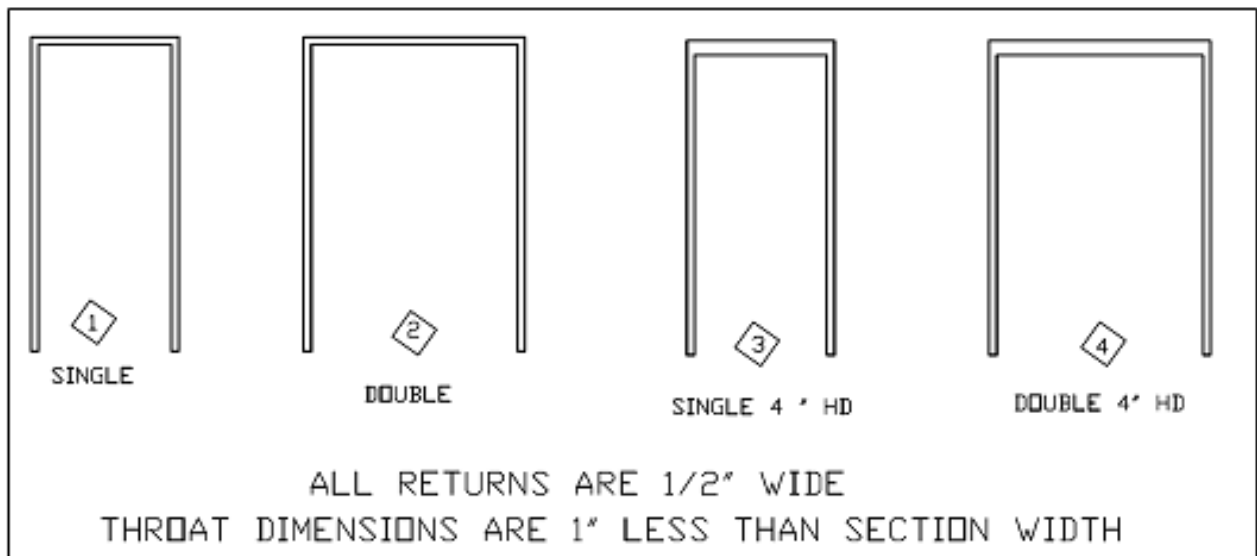

Welded Frames

Material	Galvannealed A40 ASTM-A-653
Thickness	12, 14 and 16 Ga.
Construction	Mitered and welded face and back alternatively welded face only
Appearance	Square, true and free of defects, warp and buckle
Hardware	7 Ga. 1 1/4" x 10" joggled hinge reinforcement, drilled and tapped. 12 Ga hardware reinforcements. Backwelded for additional strength. Also mortised, enforced, drilled and tapped at the factory for hardware in accordance with approved schedule and templates provided by hardware contractor. Strike jambs prepared for three rubber silencers, unless otherwise specified
Anchors	Anchors as specified. For standard frames, four 16 Ga. weld in sill anchors per jamb
Guards	Dust covers on all frames. Mortar guards on frames for masonry walls.
Spreaders	Temporary spreader bars welded to the bottom of all three sided frames. To be removed before installation
Marking	Embossed with opening numbers above the middle hinge. In the jamb for continuous hinge frames
Finish	Thoroughly cleaned and coated with a rust inhibiting primer meeting requirements as per ANSI/SDI A250.10

Typical Hardware Preparations

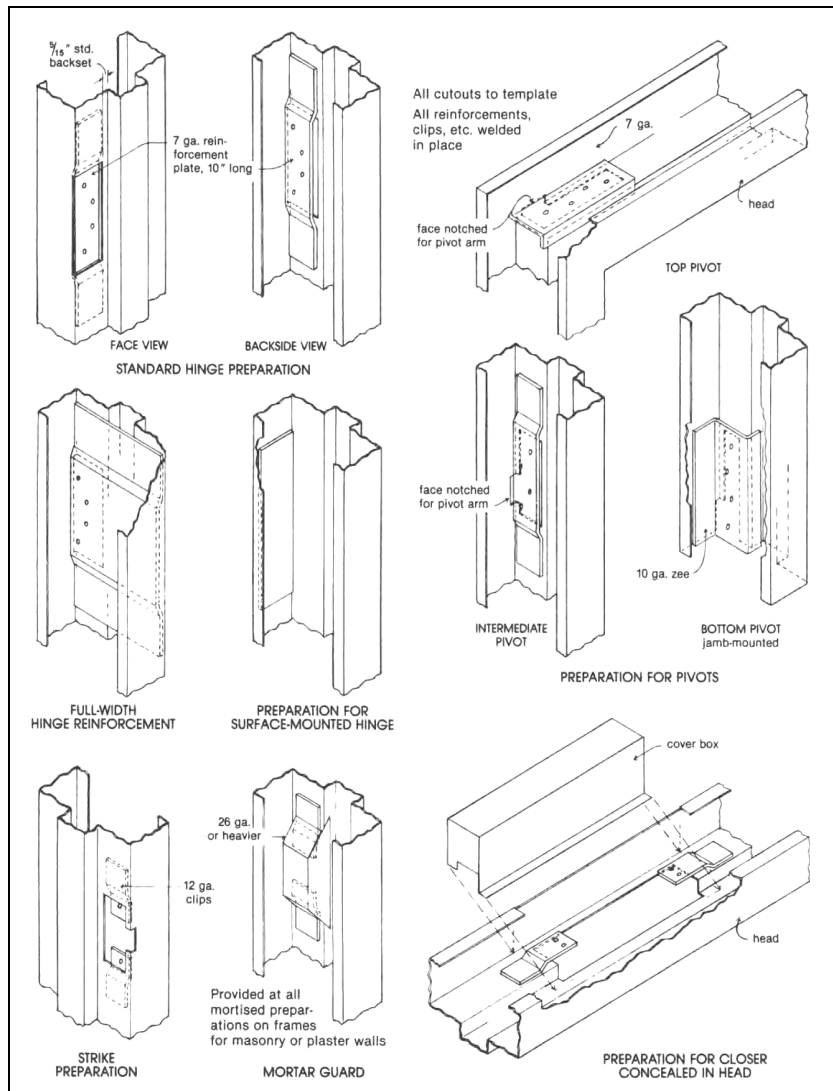

Knockdown (KD) Frames

The frames provided by Rocky Mountain Metals, Inc. are of two types. They are either made to be welded or to be installed in a pre-installed or existing drywall wall.

Material	Galvannealed A40 ASTM-A-653
Thickness	12, 14 and 16 Ga.
Construction	Mitered with self aligning tabs and slots for securely locking the corners
Appearance	Free of defects, warp and buckle
Hardware	7 Ga. 1 1/4" x 10" joggled hinge reinforcement, drilled and tapped. Back welded for additional strength. Also mortised, enforced, drilled and tapped at the factory for hardware in accordance with approved schedule and templates provided by Hardware Contractor. Strike jambs prepared for three rubber silencers, unless otherwise specified
Anchors	Anchors as specified. For standard frames, four 16 Ga. weld in sill anchors per jamb
Guards	Dust covers on all frames. Mortar guards on frames for masonry walls. KD frames for drywall walls supplied with one compression anchor per jamb
Marking	Embossed with opening numbers above the middle hinge. In the head for continuous hinge frames. Temporary marking of heads and jamb to ensure correct pairing
Finish	Thoroughly cleaned and coated with a rust inhibiting primer meeting requirements as per ANSI/SDI A250.10

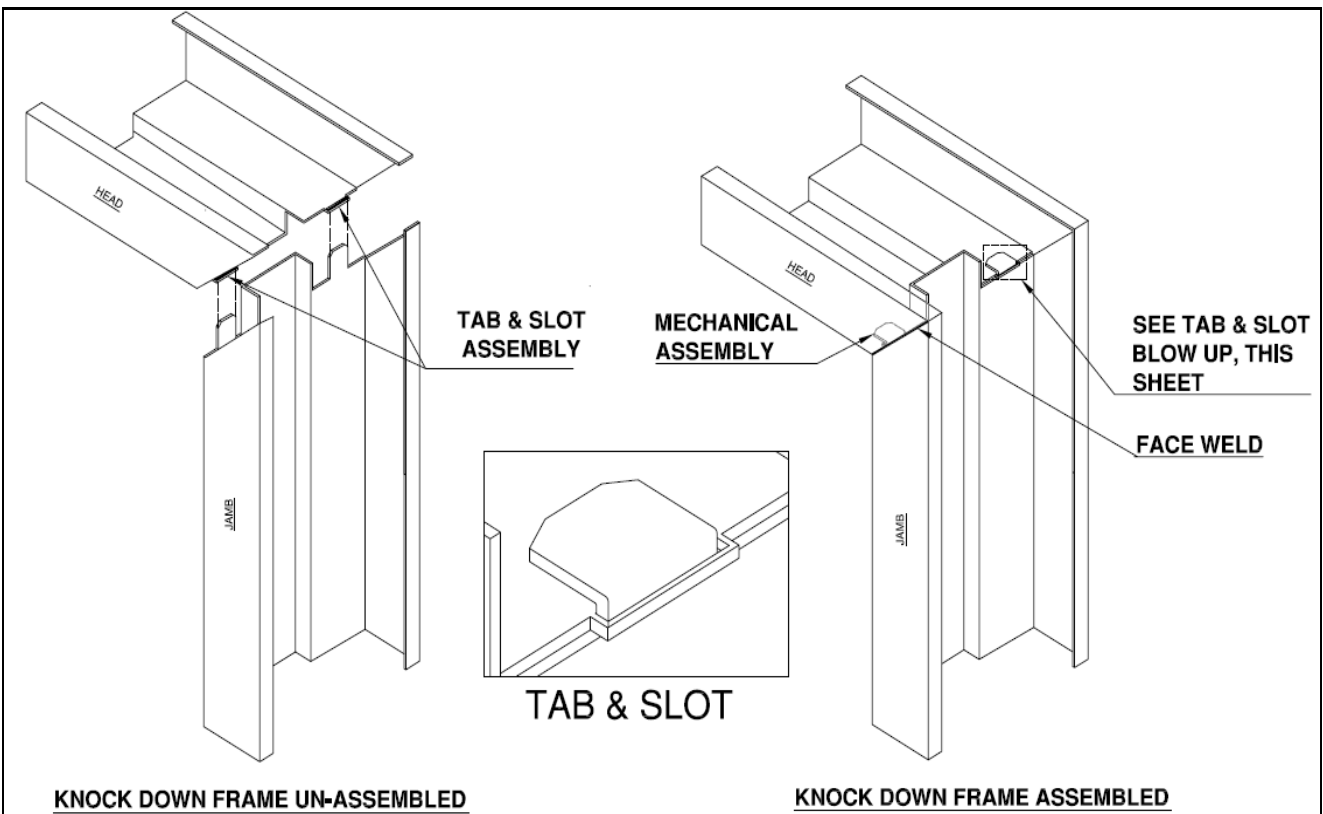

Pocket Frames

Material	Galvannealed A40 ASTM-A-653
Thickness	12, 14 and 16 Ga.
Construction	Mitered and welded face and back alternatively welded face only
Appearance	Square, true and free of defects, warp and buckle
Hardware	Optional prep to accept hardware as specified
Anchors	Anchors to meet any wall construction
Strike	Any specified location
Jamb Width	6" Standard
Guards	Dust covers on all frames. Mortar guards on frames for masonry walls.
Spreaders	Temporary spreader bars welded to the bottom of all three sided frames. To be removed before installation
Marking	Embossed with opening numbers above the middle hinge. In the jamb for continuous hinge frames
Finish	Thoroughly cleaned and coated with a rust inhibiting primer meeting requirements as per ANSI/SDI A250.10
NOTE	Sliding and tracking not provided

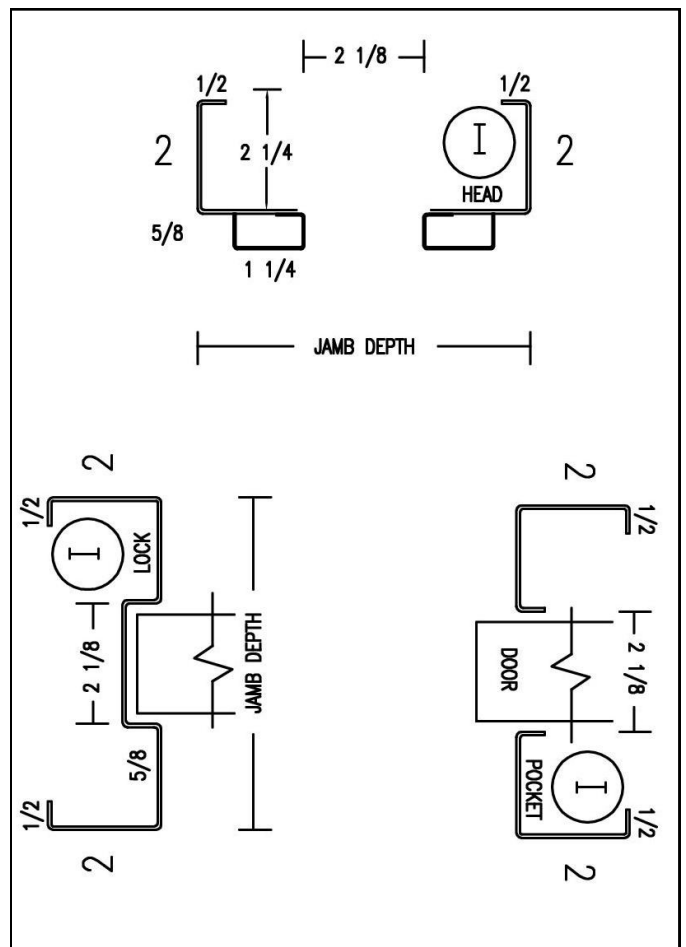
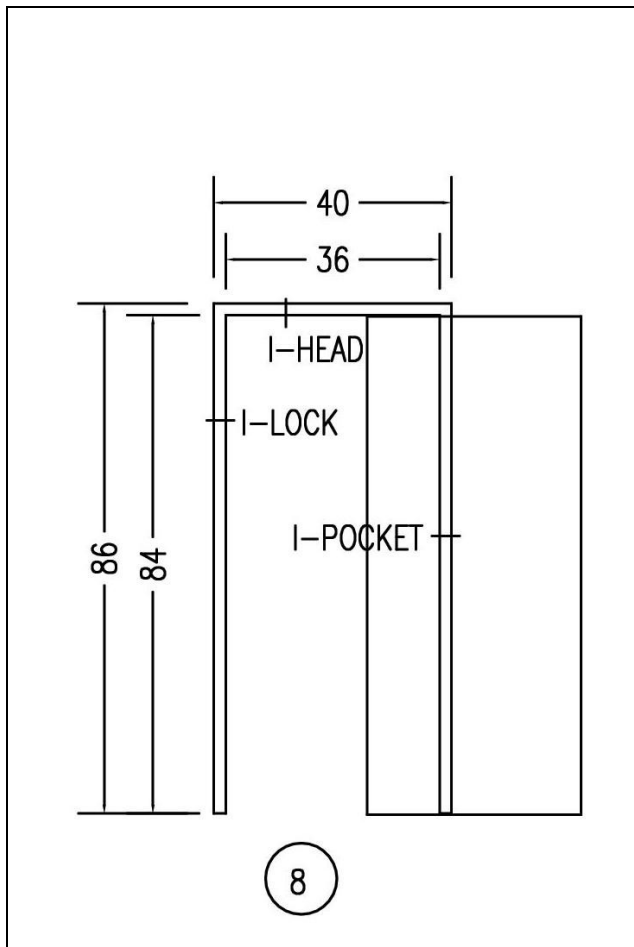

Custom Frames

Rocky Mountain Metals, Inc. has been in business since 1988 and our entire focus is on hollow metal manufacturing. Our plant is fully equipped with modern equipment to cater to your Standard and Custom Hollow Metal needs.

We have the ability to produce complex custom configurations to meet a wide variety of individual needs. Our strong focus is on quick quoting, quality, cost efficiency and quick shipping. In addition to your specific needs and specifications, our products are built by elements according to the NAAMM Standard HMMA 860, 861 and 862. We are a member of NAAMM and we manufacture products in accordance with the Steel Door Institute standards.

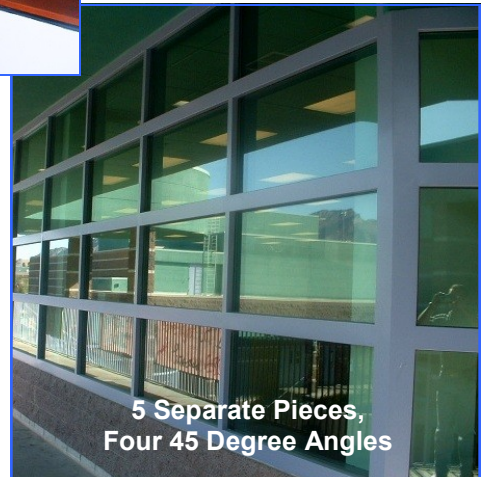

Tornado Resistant Openings



Rocky Mountain Metals, Inc. offers a complete line of **certified and labeled Tornado Openings FEMA 361/ICC 500 Compliant Opening Configurations**. These openings are tested as complete assemblies including doors, frames and hardware. Initially the Rocky Mountain Metals, Inc. solutions are certified and labeled with Securitech hardware. This program is under continued development. For up to date information contact Rocky Mountain Metals, Inc.

The offerings consists of openings of up to 8 ft. in width and 9 ft. in height for double doors and 4 ft. in width and 9 ft. in height for single doors.

FEMA 361 Tornado Resistant Openings

Rocky Mountain Metals, Inc is the proud supplier of Tornado Resistant FEMA 361/ICC 500

Bexar Metro 911 Network District
Montgomery Classic Construction
Prairie Landworks
KJ's Construction
Carbine Company
JCDM Home Builders
Haile Construction
Private Residence
Woodward Schools

San Antonio, TX
Marietta, GA
McPherson, KS
Ardmore, OK
Franklin, TN
Joplin, MO
Nashville, TN
Cumming, GA
Woodward, OK

Fram

Mater

Thick
Dime
Cons
Appe
Reinf

Hardv
Guar
Anch
Sprea

Marki

Finish

Optio

Tornado Resistant Openings

Frame Details

Material	Galvannealed A40 ASTM-A-653
Thickness	1 3/4 " Standard. 14 Ga. Galvannealed
Dimensions	2" jambs and 2" or 4" heads as specified
Construction	Mitered and welded face and back alternatively welded face only
Appearance	Square, true and free of defects, warp and buckle
Reinforcements	4 pcs 7 Ga. 1 1/4" x 10" joggled hinge reinforcement, drilled and tapped. Back welded for additional strength Strike and bolt preps 12 Ga. x 12" long, spot and MIG welded Strike jambs prepared for three rubber silencers, unless other wise specified
Hardware Locations	Any specified locations
Guards	Dust covers on all frames. Mortar guards on frames for masonry walls
Anchors	5 piece wall anchors per jamb and 2 piece head anchors for 2 double doors
Spreaders	Temporary spreader bars welded to the bottom of all three sided frames. To be removed before installation
Marking	Embossed with opening numbers above the middle hinge. In the jamb for continuous hinge frames
Finish	Thoroughly cleaned and coated with a rust inhibiting primer meeting requirements as per ANSI/SDI A250 10
Options	UL labeling requirements as specified

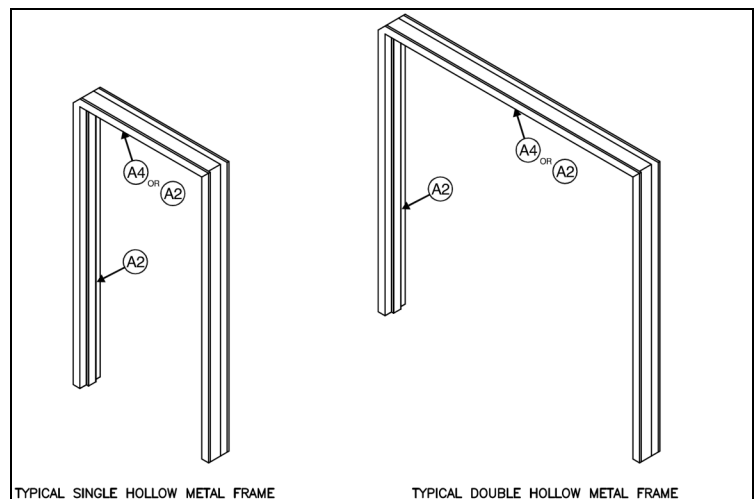
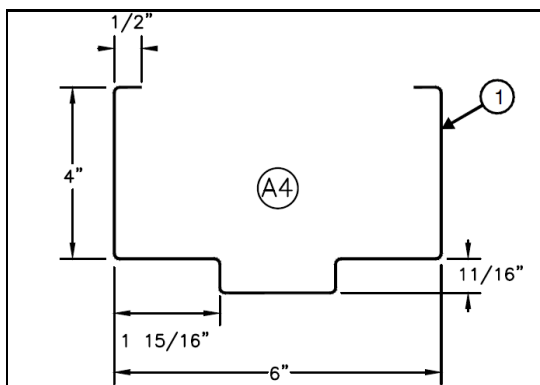
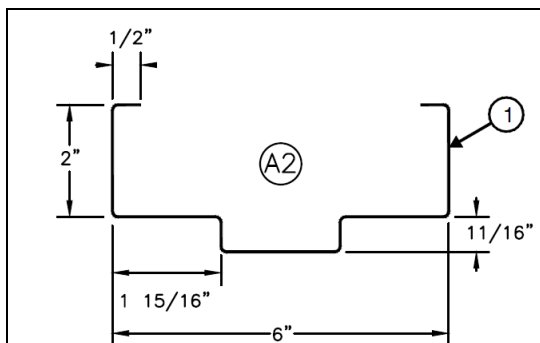

1400 Door for Tornado Resistant Openings

Face Material	Galvannealed A40 or A60 ASTM-A-653
Face thickness	14 Ga.
Construction	Hollow metal with 18 Ga. vertical steel stiffeners (ribs). Space between ribs insulated with glass wool insulation
Door thickness	1 3/4" Standard
Hardware Locations	Any specified locations
Reinforcements	7 Ga. 1 1/4" x 10" joggled hinge reinforcement, drilled and tapped 12 Ga. mortise hardware tabs, drilled and tapped 14 Ga. surface hardware and trim reinforcement, drilled and tapped
Edge reinforcement	Horizontal and vertical edges reinforced with 12 Ga. (min) full length channels spot welded to the face sheets
Vertical edges	Fully welded with no visible seam (for doors up to 10' height and 4' width)
Handing	Doors are handed
Appearance	Faces and edges free of defects, warp and buckle
Finish	Thoroughly cleaned and coated with a rust inhibiting primer meeting requirements as per ANSI/SDI A250.10
Options	UL Labeling requirements as specified

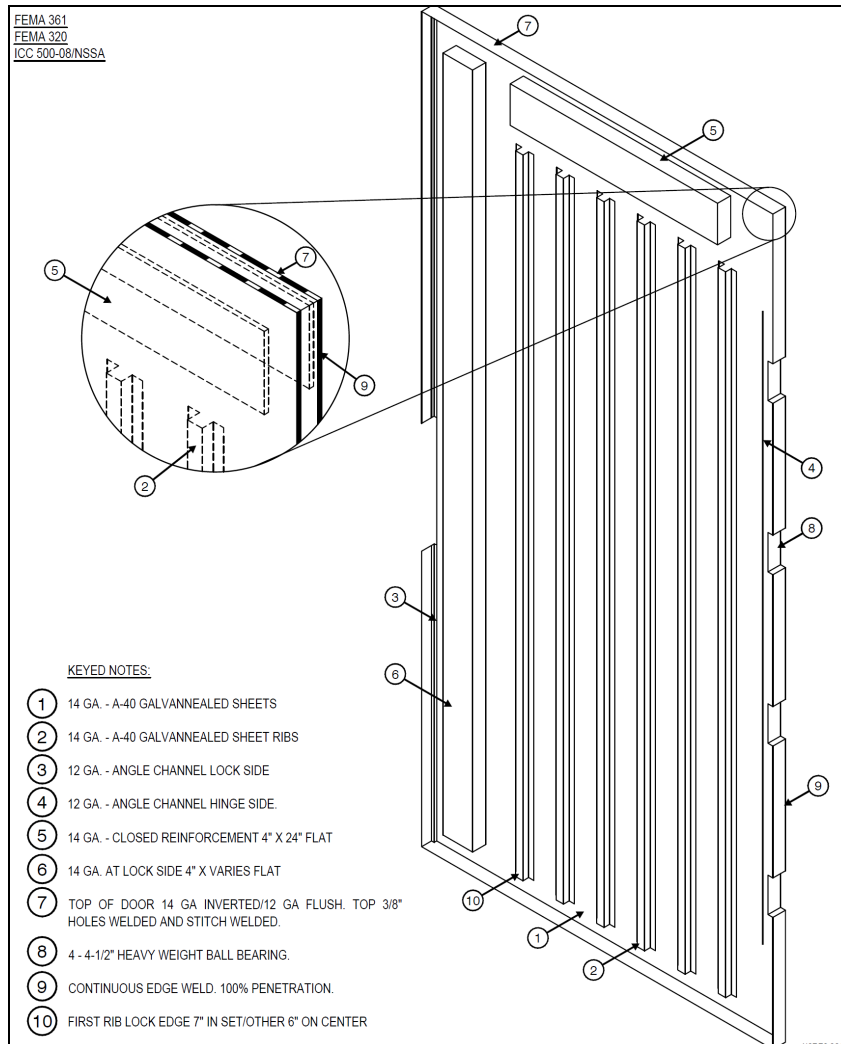

Leadership in Energy and Environmental Design (LEED)

LEED – The Leadership in Energy and Environmental Design Green Building System is the nationally accepted rating system for the design, construction and operation of sustainable and energy efficient buildings. The LEED Certification promotes a complete building system and focuses on five key areas of human and environmental health:

- Sustainable site development
- Water savings
- Energy efficiency
- Materials selection
- Indoor environmental quality

All products from Rocky Mountain Metals, Inc. qualify for LEED Credits as per below:

Full credit for recycled content MR.4.1 and 4.2 as Doors as well as Frames from Rocky Mountain Metals, Inc. contain more than 25% recycled material as per the LEED Definitions (100% of Post Consumer and 50% of Pre Consumer Recycled Content).

For further information about the requirements see below:

Credit	Requirement
Recycled Content MR 4.1	Use material with recycled content such that the sum of the post-consumer recycled content plus 50% of the pre-consumer content constitutes at least 10% of the total values of the material in the project
Recycled Content MR 4.2	Use material with recycled content such that the sum of the post-consumer recycled content plus 50% of the pre-consumer recycled content constitutes an additional 10% beyond MR 4.1 Credit (total 20%) based on cost of the total values of the material in the project
Regional Materials MR 5.1	Use a minimum of 20% of the combined value of construction and Division 12 materials and products that are manufactured (final assembly of components) within a radius of 500 miles.

Definitions:

Post-consumer recycled content – Waste material generated by households or by commercial, industrial or institutional facilities in their role as end-users of the product, which can no longer be used for its intended purposes.

Pre-consumer (post-industrial) recycled content – scraps left over during industrial or manufacturing processes, which are subsequently reused.

Contact Information

You can reach us at Rocky Mountain Metals, Inc.

Phone: 575.445.2756 Fax: 575.445.2804

Email

info@rockymountainmetals.com
sales@rockymountainmetals.com

Production / GM

Ron Gonzales rgonzales@rockymountainmetals.com

Sales and Estimating

Brittan Buchanan bbuchanan@rockymountainmetals.com
Josh Gulley jgulley@rockymountainmetals.com
Jae Leavitt jleavitt@rockymountainmetals.com

Delivery and Billing

Melanie Wahl mwahl@rockymountainmetals.com

Engineering

Larry Whitish lwhitish@rockymountainmetals.com

You can also find us online at

RockyMountainMetals.com



Questions?
Contact Us
1-575-445-2756



CERTIFICATIONS



Read more at <http://industries.ul.com/building-materials>

BUY AMERICAN ACT

All Rocky Mountain Metals, Inc. standard and custom hollow metal frames and doors are manufactured in their New Mexico manufacturing plant from materials produced substantially in the United States and as such, meet the requirements of 41 U.S.C 10, commonly known as the Buy-American Act. In addition, all Rocky Mountain Metals, Inc. products meet the “Made in USA” standards set forth by the Federal Trade Commission (FTC) Act and Enforcement Policy Statement.



MEMBER

Rocky Mountain Metals, Inc.

140 Coal St. · P.O. Box 1101 · Raton, New Mexico 87740

Phone: 575.445.2756 · Fax: 575.445.2804

info@rockymountainmetals.com

www.rockymountainmetals.com